



DUAL SHAFT SHREDDERS

DS-21060, DS-21075 & DS-21100

Ameri-Shred's Dual Shaft Shredders utilize a low speed, high torque design to easily shred a wide range of materials to a desired size.

Materials INCLUDE:

- Document Destruction
- E-Scrap & Hard Drives
- Secure Product Destruction
- Paper & Cardboard - Edgings & Cores
- Metal Stampings
- Plastics
- Textiles & Fibers
- Clothing
- Wood

Paper



Clothing



Tires



E-Scrap



Features & Options

SMALL FOOTPRINT

Right angle drives allow for a compact design, minimizing floor space.

BEARING PROTECTION

Shredded contaminants are prevented from reaching the bearings through the use of false walls and seals.

INDIVIDUAL CLEANING FINGERS

Reduces wrapping and material packing between the cutters, while being easy to remove and adjust.

CUSTOM LAYOUTS

System Engineers will work to ensure the shredder and supports fit seamlessly into your system.

CUTTER DESIGN

The number and length of hooks, as well as cutter width and material are selected to maximize throughput at the required shred size.

AUTO SHAFT REVERSAL

Improves online reliability by reorienting material to grab, preventing overfeeding, and protecting against damage from unshreddable objects.

HIGH TORQUE, LOW SPEED TECHNOLOGY

Efficiently process bulk fed, tough to shred materials. Less downtime, noise and dust emission than high speed shredders.

DUAL SHAFT SHREDDERS

DS-21060, DS-21075 & DS-21100

MODELS: DS-21060, DS-21075 & DS-21100

DRIVE	ELECTRIC
NUMBER OF MOTORS	1
HORSEPOWER	60, 75, OR 100 HP
VOLTAGE	ANY 3-PHASE
SHRED WIDTH (nominal)	5/8" - 4"
CUTTER MATERIAL	AR500 or 4140HT
CUTTER DIAMETER	15" - 17.5"
HEX SHAFT SIZE	5.75" - 6.5"
WEIGHT	9,000 - 14,000 LBS.

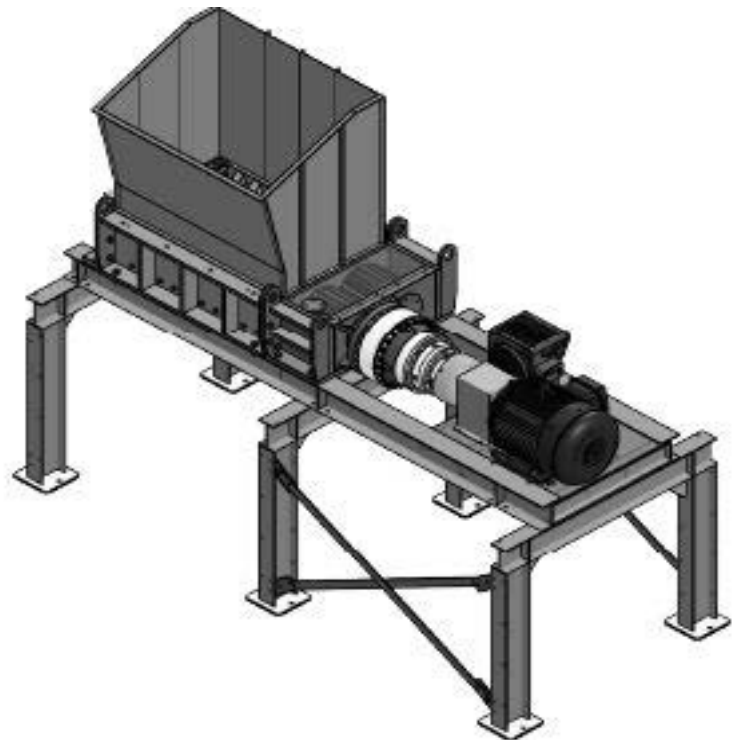
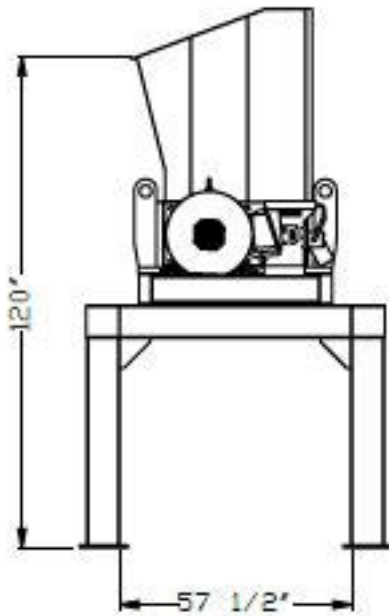
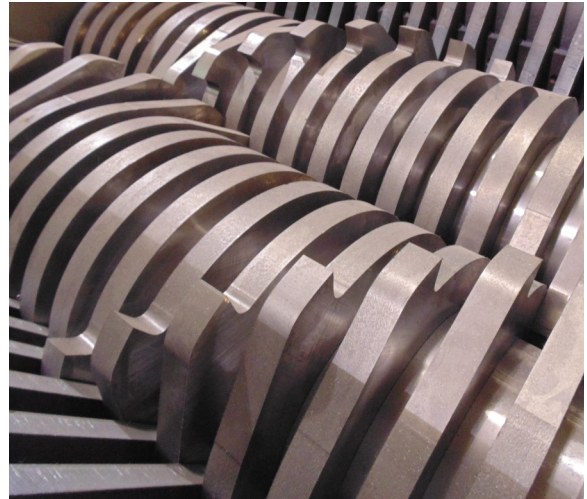

Let us provide you with a TURNKEY SOLUTION

Our team of experienced salespeople and system engineers take a special interest in what you need to shred. Everything from the cutter profile to the system layout is carefully considered to ensure you obtain the shred size and throughput you need. Our goal is to maximize the efficiency of your process with a shredder that fits seamlessly with your other equipment.